

Accessories Series

CNC FORMING
MACHINES FOR,
WIRE & TUBE



CHAMFERING UNITS

In line chamfering unit M148. The unit can perform grooves and chamfers on both ends. The wire clamping allows to obtain a high quality before the chamfering.

Model	M148
Wire Diameter	From 2 to 4 mm
Maximum chamfering depth on the radius	2.5 mm
Adjustable cycle time	From 0.5 s to 1.5 s
Inserts quantity	3

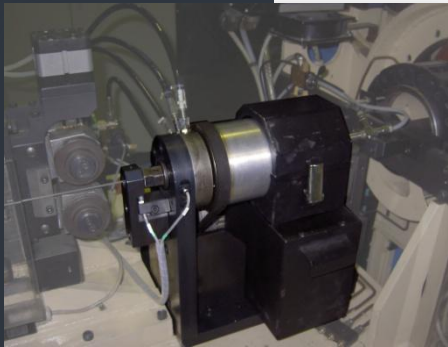

Chamfer made
on M148 unit



In line chamfering unit M143. The unit performs single or double grooves and chamfers with different angles.

Model	M143
Wire Diameter	From 3 to 12.7 mm
Maximum chamfering depth on the radius	2.5 mm
Adjustable cycle time	From 0.5 s to 1.5 s
Inserts quantity	2

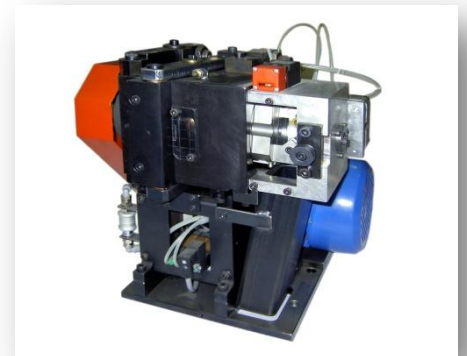

Chamfer made on
M143 unit

In line chamfering unit M168. The unit is equipped with numerical controlled head rotation speed adjustment and grippers clamping. It is therefore possible to make parts with chamfers with controlled variable depths.

Model	M168
Wire Diameter	From 10 to 24 mm
Maximum chamfering depth on radius	4 mm
Adjustable cycle time	From 0.5 s to 4 s
Inserts quantity	2

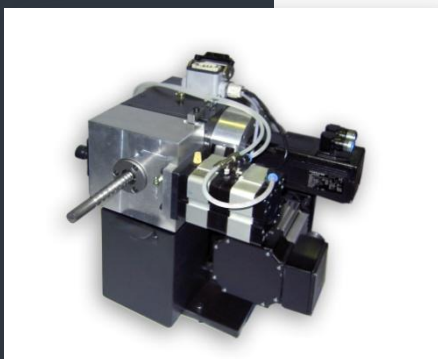

Chamfer made on
M168 unit





CHAMFERING UNITS



In line chamfering unit M154. The unit allows finishing operations on both wire ends, performs chamfer, head rounding and cutting off

Model	M154
Wire Diameter	From 3 to 12.7 mm
Maximum chamfering depth on the radius	2 mm
Adjustable cycle time	From 0.5 s. to 1.5 s
Inserts Quantity	1 + 1 cut off device



Chamfer made on M154 unit

Chamfering unit on the bending head M11907. The unit is placed on the bending head and it offers the possibility to perform a rounding on the wire end. The unit positions itself on the working line and after the chamfer, it returns back into rest position

Model	M11907
Wire Diameter	Up to 12.7 mm
Maximum chamfering depth on radius	3 mm
Adjustable cycle time	From 0.5 to 4 s
Inserts quantity	2

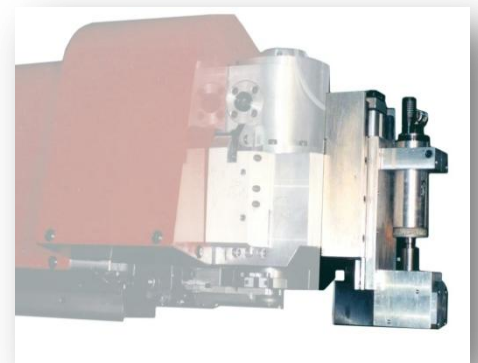

Rounded end made on M11907 unit

Le macchine sono mostrate senza protezioni di sicurezza a scopo illustrativo

Il produttore si riserva il diritto di modificare qualsiasi informazione e/o immagine fornita in questo preavviso.

OMCG s.r.l.
Via Moronata, 46
23854 Olginate (LC) ITALY
Tel. +39 0341 604244
Fax +39 0341 604247
omcg@omcg.com
www.omcg.com

North America OMCG Inc.
857 Industrial Drive
Bensenville (IL) 60106 USA
Tel. +1 630 8601016
Fax +1 630 8602333
naomcg@omcg.com
www.omcg.com

